

U S H A[®]

INSTRUCTION MANUAL

USHA care

Toll free

1800-1033-111

usha_care@ushainternational.com

USHA INTERNATIONAL LTD.

Plot No.15, Institutional Area, Sector 32, Gurgaon - 122 001 (Haryana) Tel : +91-124-4583100, Fax : +91-124-4583200

E-mail : corporate@ushainternational.com Website : www.usha.com

Regd. Office : Surya Kiran Building, 19 Kasturba Gandhi Marg, New Delhi(India) Tel : +91 11 23318114 Fax : +91 11 23318118

ISO 9001:2008
Certified Company



Fans • Sewing Machines • Home Appliances • Engines & Pumpsets • Electrical Motors & Pumps • Water Coolers & Dispensers
• Inverters • Cook Tops, Hobs & Hoods • Auto Components

U S H A © Registered Trademark and Copyright of USHA INTERNATIONAL LTD.  © Registered Trademark of USHA INTERNATIONAL LTD.

S.No.:SA3608 3756

FOOD PROCESSOR

Model - FP 2663



Dear Customer,

Congratulations!

You are now the proud owner of Usha Food Processor.

Innovatively designed, using only the highest quality material and components, your Usha Food Processor is designed for years of trouble free performance.

Please read this Instruction Manual carefully before using and keep it cautiously after reading for future reference.

Best Wishes



IMPORTANT PRECAUTIONS

- Keep the appliance out of reach of children.
- This appliance is for house hold use only.
- Switch off the appliance and disconnect it from the mains before storing it.
- Always fit the safety cover before using the food processor.
- Do not spill water on basic unit. In case it happens please get it checked from the service personnel before operating.
- Never use Food processor on wet surface as it may cause an electrical shock.
- Never push the food through feeder tube with your finger. Always cut food into small pieces and push the food into FP bowl with food pusher only.
- Never touch moving parts during operation as they revolve at high speed and may cause injury.
- Handle the blade/ discs with care as very sharp. Hold the blades from the plastic parts only.
- Never allow the processed food to touch the disc during operation. It could force the disc upward and cause damage. If bowl begins to fill, empty it out in between operations.
- Never exceed the maximum level when working with liquids.
- Always keep a visual check on food being processed till you become conversant with the Food processor. It is fast and powerful enough to finish operation before you know it.
- Never lay any cloth or plastic sheet under basic unit as it may get sucked up and block the ventilation holes in the bottom during operation.
- Place the processor bowl on base of the processor before fitting any attachments.
- All blades & attachments should be removed before cleaning.
- Don't place the appliance near hot surfaces like electrical hob, hot gas, heat oven etc.
- While using the grinder/ blender make sure there are no blades fitted in the processor.
- While using the processor grinder or blender ensure the lid is in place before switching on and do not remove the lid until the blade has stopped rotating.
- Always remove the processor blade before emptying the processor bowl of its contents.

TECHNICAL SPECIFICATIONS

| | |
|---------------------------|-----------------------------|
| Model No. | FP 2663 |
| Rating | 230V,-AC single phase, 50Hz |
| Wattage | 600 Watts |
| Type of motor | Universal motor |
| Time rating | 30 minutes |
| Speed | 3 speeds with pulse |
| Over Load Protector | Resetting type - amp |
| FP Bowl capacity | 2 ltr |
| BL Jar capacity | 1.5 ltr |
| Multipurpose Jar Capacity | 1.0 ltr. |
| Chutney Jar Capacity | 400 ml. |

*Due to continuous effort for product upgradation, specification are subject to change without prior notice.

FEATURES

- Extra powerful motor
- Over load protector to protect motor from burn out
- Unbreakable FP bowl/cover
- Safety switch for safe operation of FP bowl & jars
- Fruit Filter
- Citrus & Centrifugal juicer attachment
- Cord storage attachment

IDENTIFICATION OF PARTS

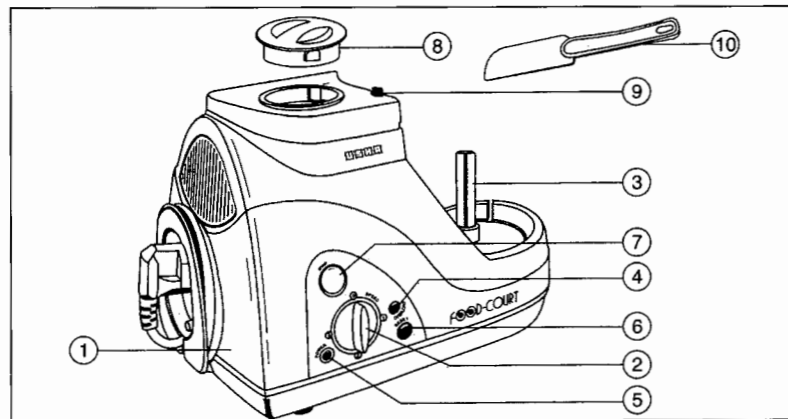

PARTS LIST

A. Main Unit

1. Basic Unit
2. Rotary Switch
3. Processor Spindle
4. Over Load Indicator
5. Power Indicator
6. Reset Button
7. Whipping Switch
8. Safety Cover
9. Safety Knob
10. Spatula

B. Bowl Assembly

11. Bowl
12. Bowl Lid
13. Feeder Tube
14. Food Pusher
15. Spindle Extension (Type A)

C. Blade Attachment

16. Kneading Blade
17. Chopping Blade
18. Blade Holder
19. Shredding Blade (Fine)
20. Shredding Blade (Course)
21. Slicing Blade
22. French Fries Blade

D. Multipurpose jar (1000 ml)

23. MP jar
24. Ring
25. Jar Lid
26. Handle

E. Blending jar (1500 ml)

27. Jar
28. Jar Lid

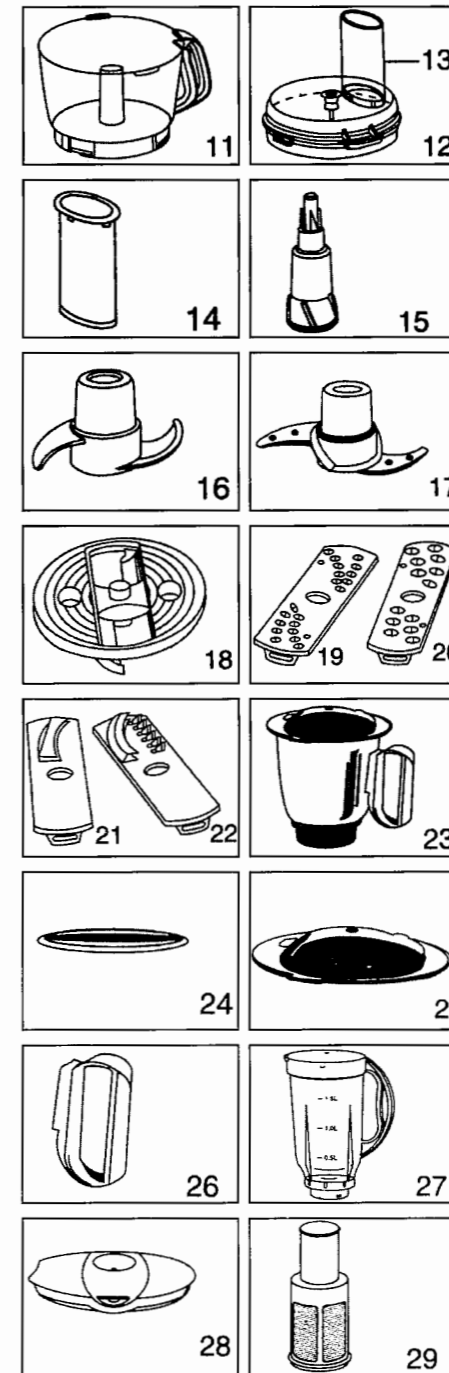

- 29. Fruit Filter
- 30. Bush Plate Assembly
- 31. Socket

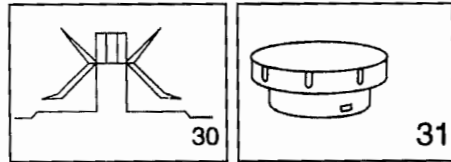

F. Chutney Jar

- 32. Jar
- 33. Ring
- 34. Lid

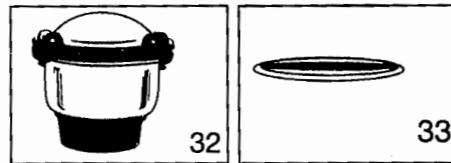

G. Juicer

- 35. Citrus Bowl
- 36. Spindle Extension (Type B)
- 37. Citrus Cone
- 38. Centrifugal Juicer
- 39. Juicer Mesh
- 40. Juicer Lid
- 41. Pusher

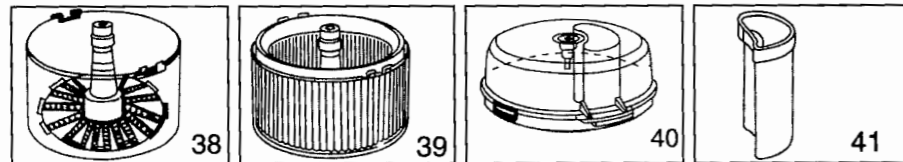
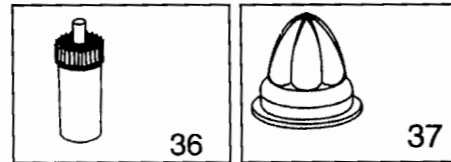
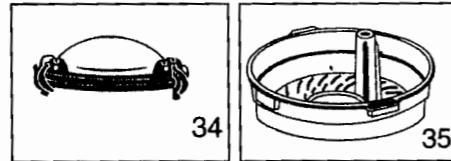

USES OF BLADES & ATTACHMENTS

| BLADES & ATTACHMENTS | USAGE | SWITCH KNOB POSITION | MAX. QTY./ CYCLE |
|----------------------|---|--|------------------|
| Kneading Blade | Atta Kneading for pie and chapati etc. This attachment can also be used for mixture for biscuit, cakes, pastries, waffles etc. (For better results, do not cover feeder tube with food pusher. Water should be added gradually as per requirement.) | Start with 1st speed and when the dough forms into a single ball move to 2nd speed | 300 gms max |
| Chopping Blade | Chopping of onions & leafy vegetable, meat mincing, tomato purees, mashing of boiled potatoes, mixing of batter for cakes. | 2nd & 3rd Speed | 500 gms |

| | | | |
|---------------------------------------|---|--|---------------|
| Shredding Blade (Fine) | Coconut for chutney, vegetables & sweets, cheese for pizza, carrots for Halwa. | 2nd & 3rd Speed | Bowl Capacity |
| Shredding Blade (course) | Dry fruit like almonds, cashew nut for biscuits, cake, sweets etc., carrots for halwa, cucumber, reddish etc. | 2nd & 3rd speed | Bowl capacity |
| Slicing Blade | Potatoes, onions, cucumbers, radish, apples, carrots etc. | 2nd & 3rd Speed | Bowl Capacity |
| French Fries Blade | Potatoes for finger chips | 2nd & 3rd Speed | Bowl Capacity |
| Citrus Juicer | Juicer for Citrus Fruits like lime, mousami etc. | 1st Speed | Bowl Capacity |
| Centrifugal Juicer | Non citrus fruits like apples, pine, apples, carrots etc. | 3rd Speed | Bowl Capacity |
| Fruit Filter (Attachment with BL jar) | Recommended for juicing of water melon, musk melon, oranges, lichi, tomatoes, grapes. | - | - |
| BL jar (1500 ml) | Cold coffee, lassi, soups, milk shakes, mango shakes etc. | Start with 1st and then after few seconds to 3rd speed | 1.2 ltrs. |
| MP jar (1000 ml.) | Grinds idli and dosa, coconut chutney, pulse, rice, dhania, pepper, garam masala, mincing etc. | Start with 1st and then after few seconds to 3rd speed | 250 gms. |
| Chutney jar | Chutney & light dry grinding (Dhania, pepper, garam masala). | Start with 1st and then after few seconds to 3rd speed | 100 gms. |

OPERATING INSTRUCTIONS

KNEADING & CHOPPING OPERATION

STEPS:

1. Ensure that the food processor unit is unplugged from the power supply.
2. Insert the safety cover into the processor body aligning marking (▼) on the safety cover with (▲) marking on the processor body. (fig. 1)
3. Turn the safety cover clockwise firmly until it clicks into place and (●) Marking on the safety cover and (▲) marking on processor body are aligned. (fig. 1)

● Safety cover
▲ Processor body

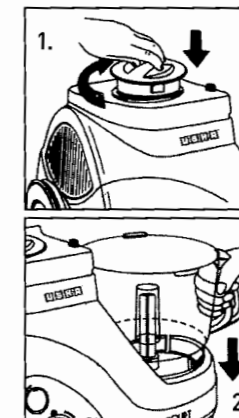

Note: The food processor will not operate unless the safety cover is fitted in its place

4. Place the processor bowl on to the processor body aligning (▼) marking on the processor bowl with (▲) marking on the processor body. (fig. 2)
5. Turn the processor bowl clockwise firmly until it clicks into place and (● & ▲) marking on the processor bowl respectively are aligned. ● Processor bowl
▲ Processor body
6. When the processor bowl is fitted correctly, the processor bowl handle will be to the right of the food processor assembly.
7. Place spindle extension (Type A) over the processor spindle. Insert the required blade on to the spindle extension. (fig. 4)
8. Fill in the flour/vegetable in the processor bowl.
9. Holding the processor bowl lid by the feeder tube fit the lid on the processor bowl and rotate clockwise till the protruding lid tab has clicked into place and the marking (●/▲) are aligned. (fig. 6)
10. Plug in the processor.
11. Run the Processor at speed 1 & 2.
12. Add water gradually through the feeder tube till dough forms into rounded lump. (In case of Kneading).
13. Allow it to run for 10 to 15 seconds, or till the desired consistency is achieved.
14. To remove the dough vegetables stop the processor, press the safety knob and hold the processes handle firmly and turn anticlockwise to unlock. (fig. 8)
15. Lift the processor bowl and unlock the processor lid.
16. Remove the dough vegetables from the processor bowl; use spatula if required.

Notes:

1. The food processor will not operate unless the safety cover is fitted in its place and the processor lid is locked.
2. To achieve best kneading action; apply light edible oil to inside surface of food processor bowl.

For chopping operation please use chopping blade instead of kneading blade as mentioned in the figure. All relevant operations shall remain same.

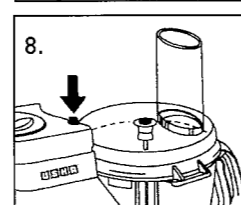
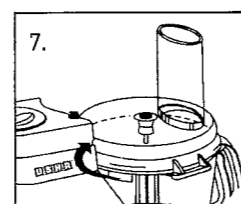
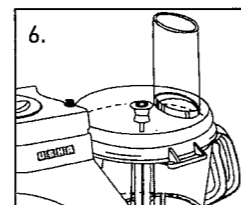
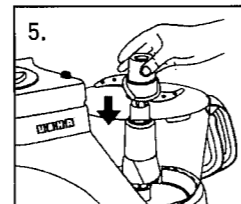
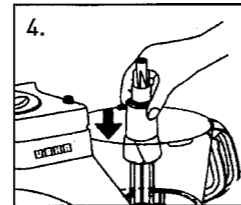
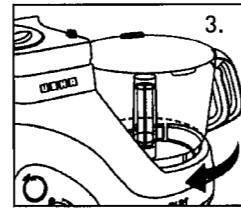

OPERATING INSTRUCTIONS

SLICING, SHREDDING & FRENCH FRIES OPERATION STEPS:

1. Follow the first 7 steps of kneading operation to fit the processor bowl.
2. Slide and snap the required blade on to the processing blade holder. (fig. 5 & 6)
3. Insert the blade holder on the spindle extension. (fig. 7)
4. Holding the processor lid by feeder tube fit the lid on the processor bowl by rotating clockwise till the protruding lid tab has clicked into place and the marking (● & ▲) are aligned. (fig. 8)
5. Plug in the processor.
6. Run the processor at speed 1 or 2. Insert vegetable in the feeder tube. Insert food pusher into the feeder tube and apply pressure. (fig. 9)
7. The slices, shredded vegetable will be collected in the processor bowl.
8. To remove the slices stop the processor, press the safety knob and hold the processor handle firmly and turn anticlockwise to unlock. (fig. 10)
9. Lift the processor bowl and unlock the processor lid.
10. Remove the processing blade holder and then the slices, shredded vegetable from the processor bowl.

NOTES:

1. The food processor will not operate unless the safety cover is fitted in its place and the processor lid is locked.
2. Caution: the stainless steel blades are very sharp, take extreme care while handling.

For shredding operation, please use shredding blades (Fine & coarse) instead of slicing blade as mentioned.

For French fries operation (Finger chips), please use finger chips blade instead of shredding or slicing operation as mentioned. All relevant operations shall remain same.

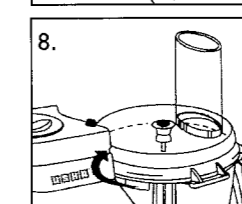
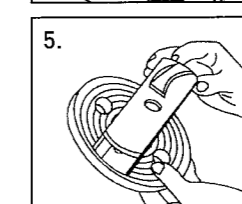
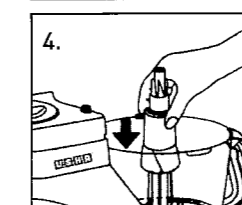
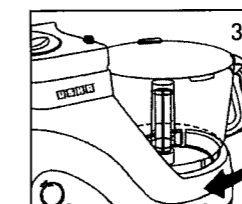
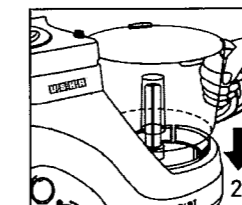
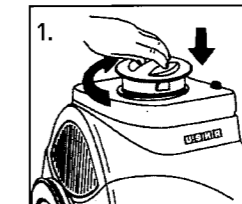
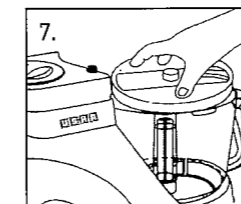
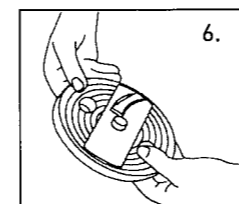

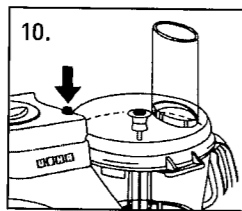
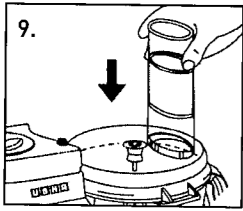

OPERATING INSTRUCTIONS

CITRUS JUICER

STEPS:

1. Ensure that the processor is unplugged from the power supply.
2. Insert the safety cover into the processor body aligning marking (▼) on the safety cover with (▲) marking on the processor body. (fig. 1)
3. Turn the safety cover clockwise firmly until it clicks into place and marking (●) on the safety cover and (▲) on the processor body are aligned. (fig. 1)

Note: the food processor will not operate unless the safety cover is fitted in its place.

4. Place the processor bowl on to the processor body aligning (▼) marking on the processor bowl with (▲) marking on the processor body. (fig. 2)
5. Turn the processor bowl clockwise firmly until it clicks into place and (● & ▲) marking on the processor bowl and the processor body respectively are aligned.

● Processor bowl
▲ Processor body

6. When the processor bowl is fitted correctly, the processor bowl handle will be to the right of the food processor assembly.
7. Place spindle extension (type B) over the processor spindle. (fig. 4)
8. Fit the citrus bowl into the processor bowl. (fig. 5)
9. Rotate the citrus bowl clockwise till the protruding lid tab has clicked into place and the markings (●/▲) are aligned. (fig. 6)
10. Insert the citrus cone into the off centred spindle. (fig. 7)
11. Plug in the processor.
12. Place half cut sweet limes on citrus cone and hold with a cupped hand.

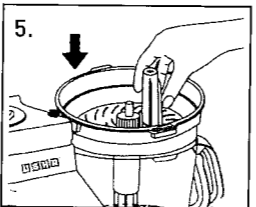
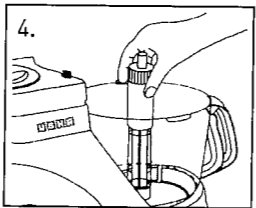
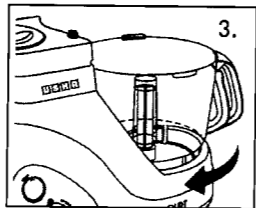
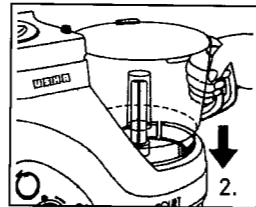
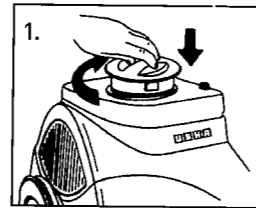

13. Run the processor at minimum speed only.
14. The juice will be collected in the processor bowl.
15. The seeds and the pulp will accumulate in the citrus bowl.
16. Remove the seeds and the pulp as and when it gets filled.
17. To remove the juice, stop the processor, press the safety knob and hold the processor handle firmly and turn anticlockwise to unlock. (fig. 8)
18. Lift the processor bowl and unlock the citrus press bowl.
19. Remove the citrus cone, citrus press bowl and then the juice from the processor bowl and store in a container.

NOTE:

1. Operate the juice at minimum speed.
2. Pulp and seeds must be removed before it starts over spilling under the citrus cone. Empty the seeds and pulp regularly.

OPERATING INSTRUCTIONS

CENTRIFUGAL JUICER

STEPS:

1. Ensure that the food processor unit is unplugged from the power supply.
2. Insert the safety cover into the processor body aligning marking (▼) on the safety cover with (▲) marking on the processor body. (fig. 1)
3. Turn the safety cover clockwise firmly until it clicks into place and marking (●) on the safety cover and (▲) on the processor body are aligned. (fig. 1)

● Safety cover
▲ Processor body

Note: The food processor will not operate unless the safety cover is fitted in its place-

4. Place the processor bowl on to the processor body aligning (▼) marking on the processor bowl with (▲) marking on the processor body. (fig. 2)
5. Turn the processor bowl clockwise firmly until it clicks into place and (● & ▲) marking on the processor bowl and the processor body respectively are aligned. (fig. 3)

● Processor bowl
▲ Processor body

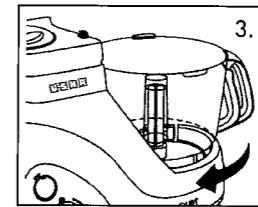
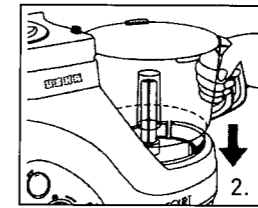
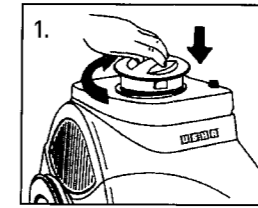
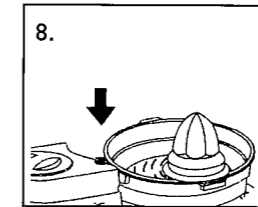
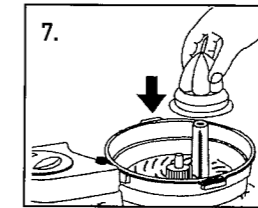
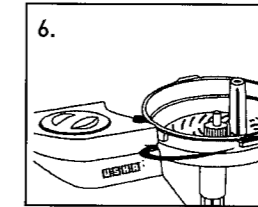

6. When the processor bowl is fitted correctly, the processor bowl handle will be to the right of the food processor assembly.
7. Place the juice extractor bowl along with juice extractor mesh over the processor spindle. (fig. 4)
8. Fit the juice extractor lid over the juice extractor and rotate clockwise ensuring that lid tab has clicked into place and the marking (●/▲) are aligned. (fig. 5)
9. Plug in the processor.
10. Run the processor at maximum speed.
11. Feed cut pieces of apple or any other non-citrus fruit through the feeder tube. (fig. 6)
12. Use the food pusher to push and press the fruit pieces. (fig. 7)
13. The juice will be collected in the processor bowl.
14. The pulp will accumulate in the juice extractor bowl.
15. If the juice extractor bowl gets clogged during operation, turn the processor OFF and remove the pulp from it.
16. To remove the juice, stop the processor, press the safety knob and hold the processor handle firmly and turn anticlockwise to unlock. (fig. 8)
17. Lift the processor bowl and unlock the juicer lid.
18. Remove the juice extractor bowl along with juicer extractor mesh and then juice from the processor bowl to be stored in a container.

Notes:

1. Operate the juicer at maximum speed.
2. Pulp must be removed before it starts over spilling. Empty the pulp regularly.

OPERATING INSTRUCTIONS

BLENDING, GRINDING AND CHUTNEY JAR OPERATION STEPS:

1. Ensure that the food processor unit is unplugged from the power supply.
2. Remove the safety cover from the processor body by turning it anticlockwise. (fig. 1)

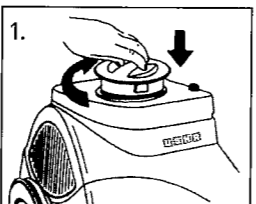
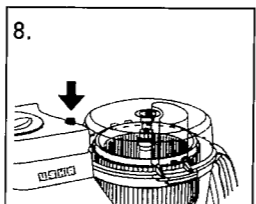
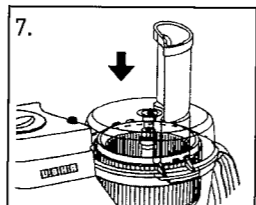
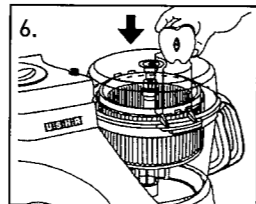
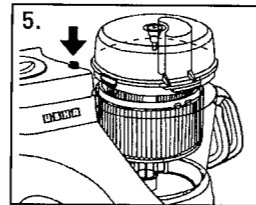
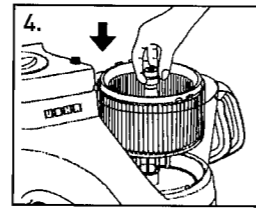

3. Place the processor bowl on the processor body aligning (▼) marking on the processor bowl with (▲) marking on the processor body. (fig. 2)
4. Turn the processor bowl clockwise firmly until it clicks into place & (●/▲) marking on the processor bowl & the processor body respectively are aligned.
5. When the processor bowl is fitted correctly, the processor bowl handle will be to the right of the food processor assembly.
6. Holding the processor or lid by the feeder tube fit the lid on the processor bowl and rotate clockwise till the protruding lid tab has clicked into place and the marking (●/▲) are aligned. Insert food pusher into the feeder tube. Ensure no processing blades, discs are fitted to the processor. (fig. 4)
7. Place the jar into its location on processor body; matching (▼&▲) marking on jar and body respectively turn clockwise until the grinder clicks in place and the marking (●/▲) are aligned. (fig. 6)
8. Place the ingredients to be ground in the jar.
9. Place the lid on the jar. (fig. 7)
10. Plug in the processor.
11. Run the processor starting with speed 1 to 3 gradually till the desired consistency is achieved.
12. Stop the processor.
13. Remove the ingredients from the jar, use spatula if required.
14. Use the jar as per required operation.

OPERATING INSTRUCTIONS

SPECIAL INSTRUCTIONS FOR USING FRUIT FILTER.

1. Place the fruit filter inside the blender jar such that its flour slots fits into the four ribs inside the blending jar. (fig. 7)
2. Press it down so that it is fixed properly.
3. Fruits should be cut into small pieces before putting inside the fruit filter for extracting the juice. (fig. 8)
4. Close the jar Lid. (fig. 9)
5. Initially use low speed and then speed can be increased.
6. After juicer is done, pour the contents into a glass.

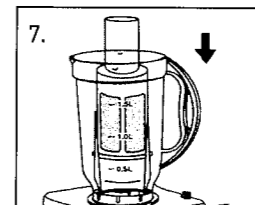
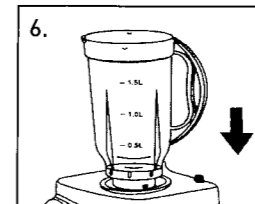
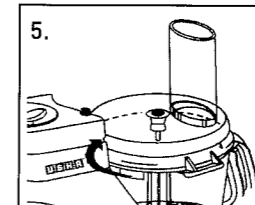
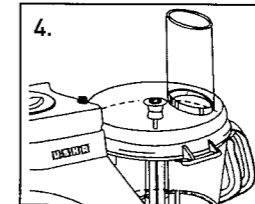
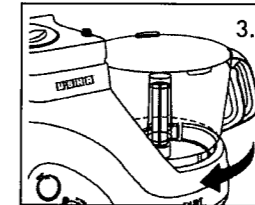
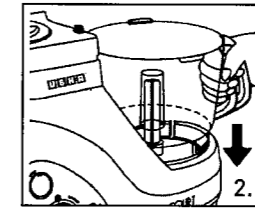

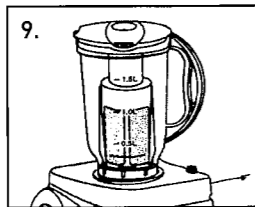
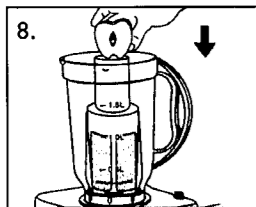

OVER LOAD PROTECTOR (OLP)

- The OLP is provided in the food processor to protect the motor from burning.
- When the jar is filled more than what is specified or the liquid is too viscous, the OLP trip indicator illuminates and the motor stops automatically.
- When this happens, reduce the quantity of ingredient being ground or add some water.
- To restart, wait for a while and press the reset button of OLP and then start the processor again.

NOTE:

1. The grinder jar will not operate unless the processor bowl is fitted in its place and the processor is locked.
2. Caution: the stainless steel blades are very sharp, take extreme care while handling.

CLEANING/MAINTENANCE

- Unplug the Food processor before cleaning.
- Remove the Bowl cover, Bowl and Blender/Dry grinder jar.
- Wash and wipe all accessories.
- Never wash the motor unit in water, wipe and clean with a dry or slightly damp cloth.
- To clean the blender fill with half litre of warm water and run at speed 2 for 10 sec.

WARRANTY CARD

This appliance is warranted for 2 years on product & 5 Years on Motor against all manufacturing defects from the date of sale. In the event of any complaint, please contact Usha Care at Toll Free No. 1800 1033 111.

The warranty is valid only when:

- 1) The appliance has been installed, used and maintained in accordance with the instruction manual.
- 2) The warranty card and cash memo duly signed by the authorized dealer are presented with the complaint.
- 3) The appliance has not been opened or tampered with, by any unauthorized person.

This warranty does not apply for:

- 1) Damages due to chipping, peeling, plating and denting.
- 2) Breakage or damage to components made out of Bakelite, Urea, ABS, SAN and such plastic materials, rubber parts and cord.
- 3) Normal wear and tear of parts.
- 4) Damage resulting from accidents, mishandling or negligence on part of the customer.

Liability for consequential loss or damage is neither accepted nor implied.

S.NO: _____ S.No.: SA3608 3756 _____

CASH MEMO _____ DATE: _____

DEALER'S NAME AND ADDRESS: _____

OWNER'S NAME & ADDRESS: _____

